

NM27LV010B 1,048,576-Bit (128k x 8) Low Voltage EPROM

General Description

The NM27LV010B is a high performance Low Voltage Electrically Programmable Read Only Memory. It is manufactured using Fairchild's latest 0.8μ CMOS split gate AMG™ EPROM technology. This technology allows the part to operate at speeds as fast as 250 ns over industrial temperatures (-40°C to +85°C).

This Low Voltage and Low Power EPROM is designed with power sensitive hand held and portable battery products in mind. This allows for code storage of firmware for applications like notebook computers, palm top computers, cellular phones, and HDD.

Small outline packages are just as critical to portable applications as Low Voltage and Low Power. Fairchild Semiconductor has foreseen this need and provides windowed LCC for prototyping and software development, PLCC for produc-

tion runs, and TSOP for PC board sensitive users. The NM27LV010B is one member of Fairchild's growing Low Voltage product family.

Features

- 2.7V to 3.6V operation
- 250 ns access time
- Low current operation
 - 8 mA I_{CC} Active Current @ 5 MHz (Typ)
 - 15 μA I_{CC} Standby Current @ 5 MHz (Typ)
- Ultra low power operation
 - 50 μW Standby Power @ 3.3V (Typ)
 - 27 mW Active Power @ 3.3V (Typ)
- Surface mount package options
 - 32-pin TSOP
 - 32-pin PLCC

Block Diagram

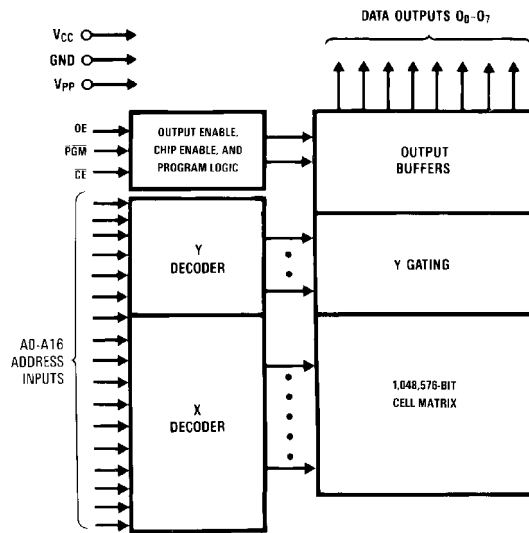

DS012333-1

AMG™ is a trademark of WSI, Incorporated.

Connection Diagrams

PLCC and CLCC Pin Configuration

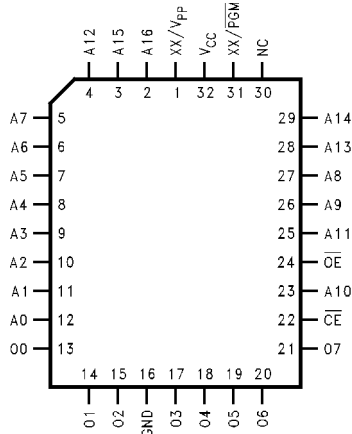

Top View

DS012333-2

Commercial Temperature Range (0°C to +70°C)

V_{CC} = 2.7V-3.6V

| Parameter/Order Number | Access Time (ns) |
|------------------------|------------------|
| NM27LV010B C, V, T 250 | 250 |
| NM27LV010B C, V, T 300 | 300 |

Pin Names

| | |
|------------------------|--------------------------|
| A0–A16 | Addresses |
| $\overline{\text{CE}}$ | Chip Enable |
| $\overline{\text{OE}}$ | Output Enable |
| O0–O7 | Outputs |
| PGM | Program |
| XX | Don't Care (During Read) |
| V _{PP} | Programming Voltage |

TSOP Pin Configuration

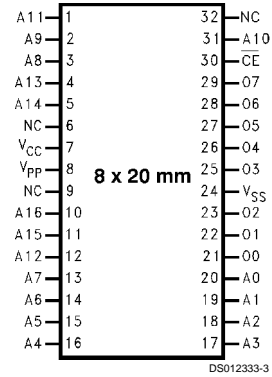

Top View

DS012333-3

Industrial Temperature Range (–40°C to +85°C)

V_{CC} = 2.7V–3.6V

| Parameter/Order Number | Access Time (ns) |
|------------------------|------------------|
| NM27LV010B CE, VE, TE | 250 |
| NM27LV010B CE, VE, TE | 300 |

Package Types: NM27LV010B C, V, T

C = Quartz-Windowed LCC Package

V = PLCC Package

T = TSOP Package

- All packages conform to JEDEC standard.
- All versions are guaranteed to function at slower speeds.
- Consult your Fairchild Semiconductor sales office for new released products and packages.
- Consult your Fairchild Semiconductor representative for custom products for your specific application.

Absolute Maximum Ratings (Note 1)

| | |
|--|-----------------|
| Storage Temperature | -65°C to +150°C |
| All Input Voltage except A9 with Respect to Ground | -0.6V to +7V |
| V _{PP} and A9 with Respect to Ground | -0.7V to +14V |
| V _{CC} Supply Voltage with Respect to Ground | -0.6V to +7V |
| ESD Protection | >2000V |

All Output Voltages
with Respect to Ground
(Note 10) V_{CC} + 1.0V
to GND - 0.6V

Operating Range

| Range | Temperature | V _{CC} | Tolerance |
|------------|----------------|-----------------|-----------|
| Commercial | 0°C to +70°C | 2.7V-3.6V | |
| Industrial | -40°C to +85°C | 2.7V-3.6V | |

DC Read Characteristics

(Over Operating Range with V_{PP} = V_{CC})

| Symbol | Parameter | Conditions | Min | Max | Units |
|------------------|---|--|-----------------------|-----------------------|-------|
| V _{IL} | Input Low Level | | -0.3 | 0.6 | V |
| V _{IH} | Input High Level | | 2.0 | V _{CC} + 0.3 | V |
| V _{OL1} | Output Low Voltage (TTL) | I _{OL} = 2.1 mA | | 0.4 | V |
| V _{OH1} | Output High Voltage (TTL) | I _{OH} = -400 µA | 2.2 | | V |
| V _{OL2} | Output Low Voltage | I _{OL} = 100 µA | | 0.2 | V |
| V _{OH2} | Output High Voltage (CMOS) | I _{OH} = 100 µA | V _{CC} - 0.3 | | V |
| I _{SB1} | V _{CC} Standby Current (CMOS) | $\overline{CE} = 2.7V-3.6V$ | | 50 | µA |
| I _{SB2} | V _{CC} Standby Current (TTL) | $\overline{CE} = V_{IH}$ | | 1 | mA |
| I _{CC} | V _{CC} Active Current | $\overline{CE} = \overline{OE} = V_{IL}$, I/O = 0 µA | f = 5 MHz | 15 | mA |
| I _{PP} | V _{PP} Supply Current | V _{PP} = V _{CC} | | 10 | µA |
| I _{LI} | Input Load Current | V _{IN} = 3.0V or GND | | 1 | µA |
| I _{LO} | Output Leakage Current | V _{OUT} = 3.3V or GND | -1 | 10 | µA |

AC Read Characteristics

(Over Operating Range with V_{PP} = V_{CC})

| Symbol | Parameter | 250 | | 300 | | Units |
|------------------|--|-----|-----|-----|-----|-------|
| | | Min | Max | Min | Max | |
| t _{ACC} | Address to Output Delay | | 250 | | 300 | ns |
| t _{CE} | \overline{CE} to Output Delay | | 250 | | 250 | ns |
| t _{OE} | \overline{OE} to Output Delay | | 75 | | 75 | ns |
| t _{DF} | Output Disable to Output Float (Note 2) | | 50 | | 50 | ns |
| t _{OH} | Output Hold from Addresses, \overline{CE} or \overline{OE} , Whichever Occurred First (Note 2) | 0 | | 0 | | ns |

Capacitance

$T_A = +25^\circ\text{C}$, $f = 1\text{ MHz}$ (Note 2)

| Symbol | Parameter | Conditions | Typ | Max | Units |
|-----------|--------------------|-----------------------|-----|-----|-------|
| C_{IN1} | Input Capacitance | $V_{IN} = 0\text{V}$ | 9 | 15 | pF |
| C_{OUT} | Output Capacitance | $V_{OUT} = 0\text{V}$ | 12 | 15 | pF |

AC Test Conditions

Output Load: 1 TTL Gate and
 $CL = 100\text{ pF}$ (Note 8)

Input Rise and Fall Times: $\leq 5\text{ ns}$

Input Pulse Levels: 0.45V to 2.4V

Timing Measurement Reference Level

Inputs: 0.8V and 2V

Outputs: 0.8V and 2V

AC Waveforms (Note 6) (Note 7) (Note 9)

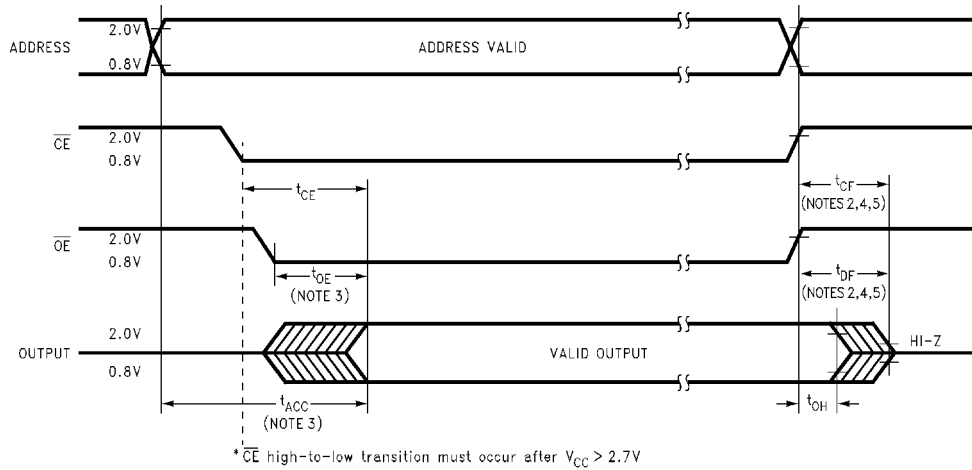

DS012333-4

*After power-up (stable V_{CC}), a high-to-low transition of \overline{CE} is required before the first byte of data is read.

Note 1: Stresses above those listed under "Absolute Maximum Ratings" may cause permanent damage to the device. This is a stress rating only, and functional operation of the device at these or any other conditions above those indicated in the operational sections of the specification is not implied. Exposure to absolute maximum rating conditions for extended periods may affect device reliability.

Note 2: This parameter is only sampled and is not 100% tested.

Note 3: \overline{OE} may be delayed up to $t_{ACC} - t_{OE}$ after the falling edge of \overline{CE} without impacting t_{ACC} .

Note 4: The t_{DF} and t_{CF} compare level is determined as follows: High to TRI-STATE[®], the measured V_{OH1} (DC) - 0.10V; Low to TRI-STATE, the measured V_{OL1} (DC) + 0.10V.

Note 5: TRI-STATE may be attained using \overline{OE} or \overline{CE} .

Note 6: The power switching characteristics of EPROMs require careful device decoupling. It is recommended that at least a 0.1 μF ceramic capacitor be used on every device between V_{CC} and GND.

Note 7: The outputs must be restricted to $V_{CC} + 1.0\text{V}$ to avoid latch-up and device damage.

Note 8: 1 TTL Gate: $I_{OL} = 1.6\text{ mA}$, $I_{OH} = -400\text{ }\mu\text{A}$. C_L : 100 pF includes fixture capacitance.

Note 9: V_{PP} may be connected to V_{CC} except during programming.

Note 10: Inputs and outputs can undershoot to -2.0V for 20 ns max.

Programming Characteristics (Note 11) (Note 12) (Note 13) (Note 14)

| Symbol | Parameter | Conditions | Min | Typ | Max | Units |
|-----------|--|---|------|-------|------|--------------------|
| t_{AS} | Address Setup Time | | 1 | | | μs |
| t_{OES} | \overline{OE} Setup Time | | 1 | | | μs |
| t_{CES} | \overline{CE} Setup Time | | 1 | | | |
| t_{DS} | Data Setup Time | | 1 | | | μs |
| t_{VPS} | V_{PP} Setup Time | | 1 | | | |
| t_{VCS} | V_{CC} Setup Time | | 1 | | | μs |
| t_{AH} | Address Hold Time | | 0 | | | μs |
| t_{DH} | Data Hold Time | | 1 | | | μs |
| t_{DF} | Output Enable to Output Float Delay | $\overline{CE} / \overline{PGM} = V_{IL}$ | 0 | | 60 | ns |
| t_{PW} | Program Pulse Width | | 45 | 50 | 55 | μs |
| t_{OE} | Data Valid from \overline{OE} | $\overline{CE} / \overline{PGM} = V_{IL}$ | | | 100 | μs |
| I_{PP} | V_{PP} Supply Current during Programming Pulse | $\overline{CE} / \overline{PGM} = V_{IL}$ | | | 20 | mA |
| I_{CC} | V_{CC} Supply Current | | | | 20 | mA |
| T_A | Temperature Ambient | | 20 | 25 | 30 | $^{\circ}\text{C}$ |
| V_{CC} | Power Supply Voltage | | 6.25 | 6.5 | 6.75 | V |
| V_{PP} | Programming Supply Voltage | | 12.5 | 12.75 | 13 | V |
| t_{FR} | Input Rise, Fall Time | | 5 | | | ns |
| V_{IL} | Input Low Voltage | | | 0 | 0.45 | V |
| V_{IH} | Input High Voltage | | 2.4 | 4 | | V |
| t_{IN} | Input Timing Reference Voltage | | 0.8 | | 2 | V |
| t_{OUT} | Output Timing Reference Voltage | | 0.8 | | 2 | V |

Programming Waveform (Note 13)

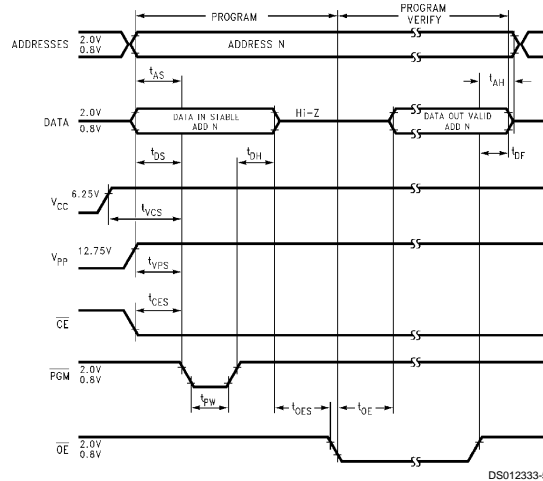

Note 11: Fairchild's standard product warranty applies only to devices programmed to specifications described herein.

Note 12: V_{CC} must be applied simultaneously or before V_{PP} and removed simultaneously or after V_{PP} . The EPROM must not be inserted into or removed from a board with voltage applied to V_{PP} or V_{CC} .

Note 13: The maximum absolute allowable voltage which may be applied to the V_{PP} pin during programming is 14V. Care must be taken when switching the V_{PP} supply to prevent any overshoot from exceeding this 14V maximum specification. At least a 0.1 μF capacitor is required across V_{CC} to GND to suppress spurious voltage transients which may damage the device.

Note 14: During power up, the PGM pin must be brought high (V_{IH}) either coincident with or before power is applied to V_{PP} .

LV Turbo Programming Algorithm Flow Chart

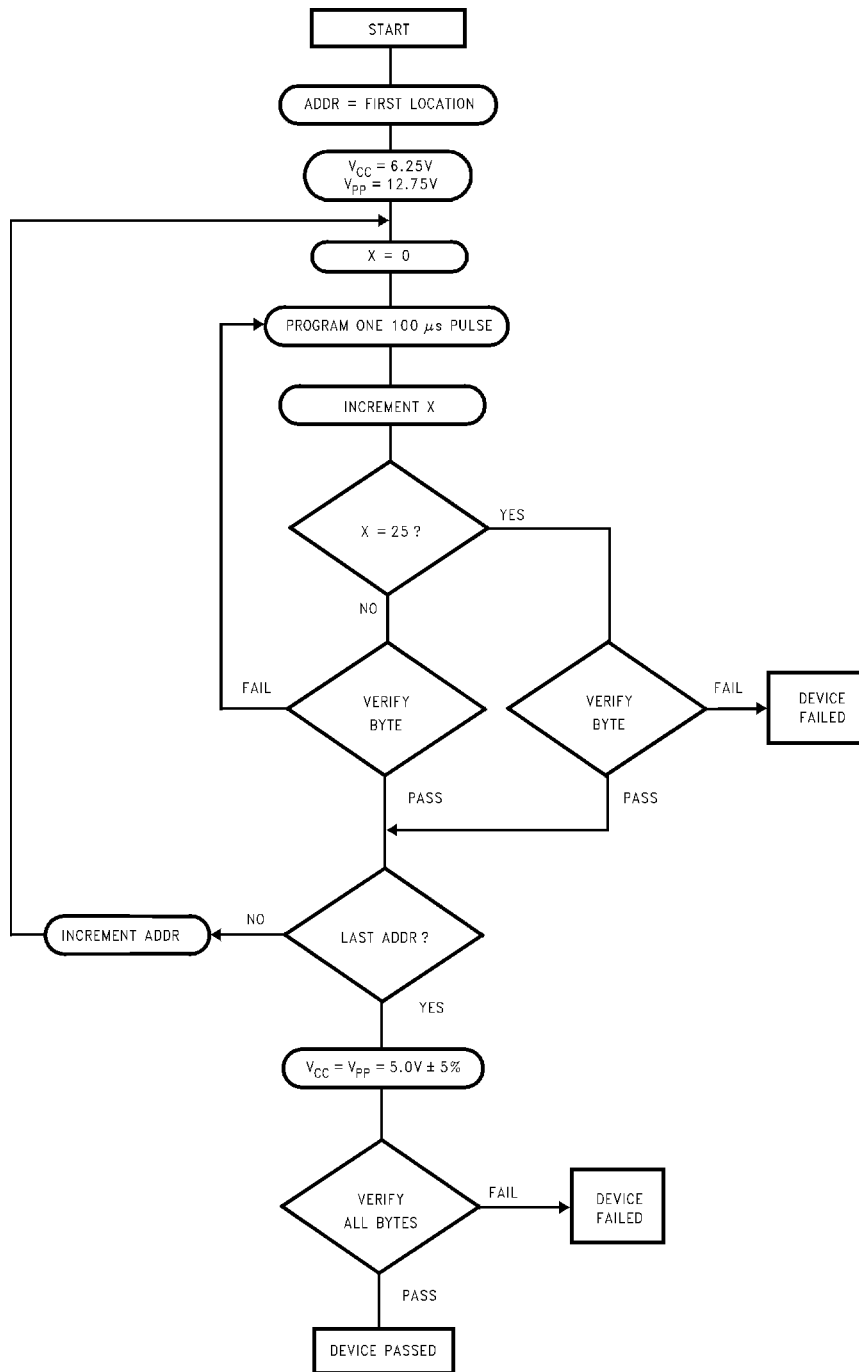

FIGURE 1.

DS012333-6

Functional Description

DEVICE OPERATION

The six modes of operation of the EPROM are listed in Table I. It should be noted that all inputs for the six modes are at TTL levels. The power supplies required are V_{CC} and V_{PP} . The V_{PP} power supply must be at 12.75V during the three programming modes, and must be at 3.3V in the other three modes. The V_{CC} power must be at 6.25V during the three programming modes, and at 3.3V in the other three modes.

Read Mode

The EPROM has two control functions, both of which must be logically active in order to obtain data at the outputs. Chip Enable (\overline{CE}) is the power control and should be used for device selection. Output Enable (\overline{OE}) is the output control and should be used to gate data to the output pins, independent of device selection. Assuming that addresses are stable, address access time (t_{ACC}) is equal to the delay from \overline{CE} to output (t_{CE}). Data is available at the outputs t_{OE} after the falling edge of \overline{OE} , assuming that \overline{CE} has been low and addresses have been stable for at least $t_{ACC} - t_{OE}$.

Standby Mode

The EPROM has a standby mode which reduces the active power dissipation by over 99%, from 2.7 mW to 50 μ W. The EPROM is placed in the standby mode by applying a CMOS high signal to the \overline{CE} input. When in standby mode, the outputs are in a high impedance state, independent of the \overline{OE} input.

Output Disable

The EPROM is placed in output disable by applying a TTL high signal to the \overline{OE} input. When in output disable all circuitry is enabled, except the outputs are in a high impedance state (TRI-STATE).

Output OR-Tying

Because the EPROM is usually used in larger memory arrays, Fairchild has provided a 2-line control function that accommodates this use of multiple memory connections. The 2-line control function allows for:

1. the lowest possible memory power dissipation, and
2. complete assurance that output bus contention will not occur.

To most efficiently use these two control lines, it is recommended that \overline{CE} be decoded and used as the primary device selecting function, while \overline{OE} be made a common connection to all devices in the array and connected to the READ line from the system control bus. This assures that all selected memory devices are in their low power standby modes and that the output pins are active only when data is desired from a particular memory device.

Programming

CAUTION: Exceeding 14V on pin 22 (V_{PP}) will damage the EPROM.

Initially, and after each erasure, all bits of the EPROM are in the "1's" state. Data is introduced by selectively programming "0's" into the desired bit locations. Although only "0's" will be programmed, both "1's" and "0's" can be presented in the data word. The only way to change a "0" to a "1" is by ultraviolet light erasure.

The EPROM is in the programming mode when the V_{PP} power supply is at 12.75V and \overline{OE} is at V_{IH} . It is required that at least a 0.1 μ F capacitor be placed across V_{CC} to GND to suppress spurious voltage transients which may damage the

device. The data to be programmed is applied 8 bits in parallel to the data output pins. The levels required for the address and data inputs are TTL.

When the address and data are stable, an active low, TTL program pulse is applied to the PGM input. A program pulse must be applied at each address location to be programmed.

The EPROM is programmed with the LV Turbo Programming Algorithm shown in Figure 1. Each address is programmed with a series of 50 μ s pulses until it verifies good, up to a maximum of 10 pulses. Most memory cells will program with a single 50 μ s pulse. (The standard National Semiconductor Algorithm may also be used, but it will have longer programming time.)

The EPROM must not be programmed with a DC signal applied to the PGM input.

Programming multiple EPROMs in parallel with the same data can be easily accomplished due to the simplicity of the programming requirements. Like inputs of the parallel EPROM may be connected together when they are programmed with the same data. A low level TTL pulse applied to the PGM input programs the paralleled EPROM.

Program Inhibit

Programming multiple EPROMs in parallel with different data is also easily accomplished. Except for \overline{CE} , all like inputs (including \overline{OE} and PGM) of the parallel EPROM may be common. A TTL low level program pulse applied to an EPROM's PGM input with \overline{CE} at V_{IL} and V_{PP} at 12.75V will program that EPROM. A TTL high level \overline{CE} input inhibits the other EPROMs from being programmed.

Program Verify

A verify should be performed on the programmed bits to determine whether they were correctly programmed. The verify may be performed with V_{PP} at 6.25V. V_{PP} must be at V_{CC} except during programming and program verify.

AFTER PROGRAMMING

Opaque labels should be placed over the EPROM window to prevent unintentional erasure. Covering the window will also prevent temporary functional failure due to the generation of photo currents.

MANUFACTURER'S IDENTIFICATION CODE

The EPROM has a manufacturer's identification code to aid in programming. When the device is inserted in an EPROM programmer socket, the programmer reads the code and then automatically calls up the specific programming algorithm for the part. This automatic programming control is only possible with programmers which have the capability of reading the code.

The manufacturer's identification code, shown in Table 2, specifically identifies the manufacture and device type. The code for NM27LV010B is "8F86", where "8F" designates that it is made by Fairchild Semiconductor, and "86" designates a 1 Mbit (128k x 8) part.

The code is accessed by applying $12V \pm 0.5V$ to address pin A9. Addresses A1–A8, A10–A16 and all control pins are held at V_{IL} . Address pin A0 is held at V_{IL} for the manufacturer's code and held at V_{IH} for the device code. The code is read on the eight data pins, O0–O7. Proper code access is only guaranteed at $25^{\circ}C \pm 5^{\circ}C$.

Functional Description (Continued)

ERASURE CHARACTERISTICS

The erasure characteristics of the device are such that erasure begins to occur when exposed to light with wavelengths shorter than approximately 4000 Angstroms (Å). It should be noted that sunlight and certain types of fluorescent lamps have wavelengths in the 3000Å–4000Å range.

The recommended erasure procedure for the EPROM is exposure to short wave ultraviolet light which has a wavelength of 2537Å. The integrated dose (i.e., UV intensity x exposure time) for erasure should be a minimum of 30 Wsec/cm².

The EPROM should be placed within one inch of the lamp tubes during erasure. Some lamps have a filter on their tubes which should be removed before erasure.

An erasure system should be calibrated periodically. The distance from lamp to device should be maintained at one inch. The erasure time increases at the square of the distance from the lamp (if distance is doubled the erasure time increases by factor of four). Lamps lose intensity as they age. When a lamp is changed, the distance has changed or the lamp has aged, the system should be checked to make certain full erasure is occurring. Incomplete erasure will cause

symptoms that can be misleading. Programmers, components, and even system designs have been erroneously suspected when incomplete erasure was the problem.

SYSTEM CONSIDERATION

The power switching characteristics of EPROMs require careful decoupling of the devices. The supply current, I_{CC} , has three segments that are of interest to the system designer: the standby current level, the active current level and the transient current peaks that are produced by voltage transitions on input pins. The magnitude of these transient current peaks is dependent on the output capacitance loading of the device. The associated V_{CC} transient voltage peaks can be suppressed by properly selected decoupling capacitors. It is recommended that at least a 0.1 μF ceramic capacitor be used on every device between V_{CC} and GND. This should be a high frequency capacitor of low inherent inductance. In addition, at least a 4.7 μF bulk electrolytic capacitor should be used between V_{CC} and GND for each eight devices. The bulk capacitor should be located near where the power supply is connected to the array. The purpose of the bulk capacitor is to overcome the voltage drop caused by the inductive effects of the PC board traces.

Mode Selection

The modes of operation of the NM27LV010B are listed in Table 1. All inputs are TTL levels except for V_{PP} and A9 for device signature.

TABLE 1. Modes Selection

| | Pins | \overline{CE} | \overline{OE} | \overline{PGM} | V_{PP} | V_{CC} | Outputs |
|-----------------|------|-----------------|-----------------|------------------|----------|----------|-----------|
| Mode | | | | | | | |
| Read | | V_{IL} | V_{IL} | X | V_{CC} | 3.3V | D_{OUT} |
| Output Disable | | X | V_{IH} | X | V_{CC} | 3.3V | High Z |
| Standby | | V_{IH} | X | X | V_{CC} | 3.3V | High Z |
| Programming | | V_{IL} | V_{IH} | V_{IL} | 12.75V | 6.25V | D_{IN} |
| Program Verify | | V_{IL} | V_{IL} | V_{IH} | 12.75V | 12.75V | D_{OUT} |
| Program Inhibit | | V_{IH} | V_{IH} | X | 12.75V | 6.25V | High Z |

X can be V_{IL} or V_{IH}

TABLE 2. Manufacturer's Identification Code

| Pins | A0 (12) | A9 (26) | O7 (21) | O6 (20) | O5 (19) | O4 (18) | O3 (17) | O2 (15) | O1 (14) | O0 (13) | Hex Data |
|-------------------|------------|------------|------------|------------|------------|------------|------------|------------|------------|------------|-------------|
| Manufacturer Code | V_{IL} | 12V | 1 | 0 | 0 | 0 | 1 | 1 | 1 | 1 | 8F |
| Device Code | V_{IH} | 12V | 1 | 0 | 0 | 0 | 0 | 1 | 1 | 0 | 86 |

Physical Dimensions inches (millimeters) unless otherwise noted

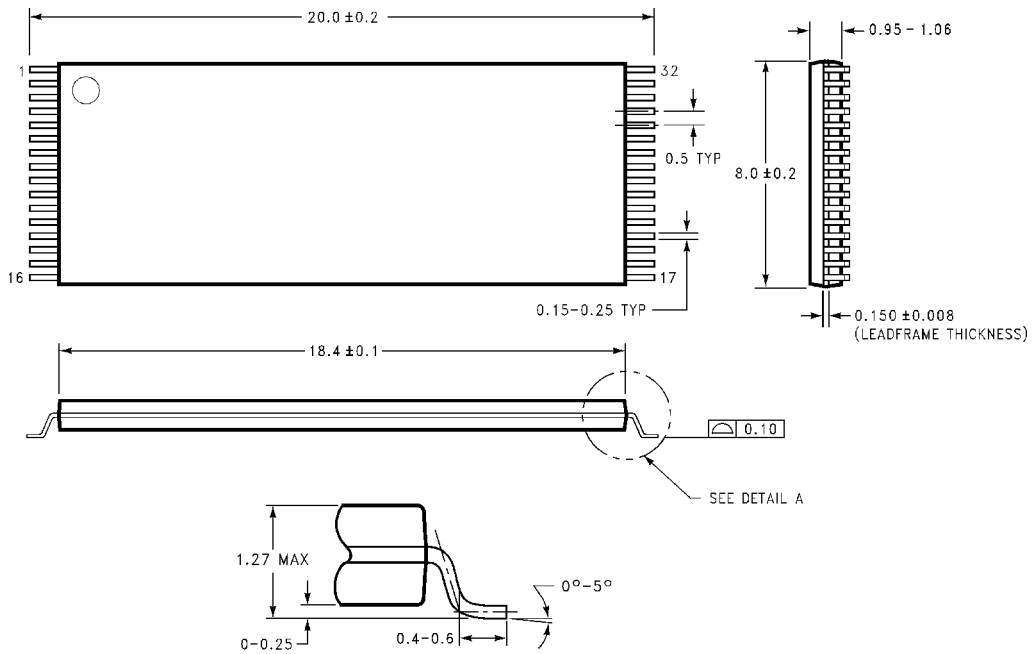

DETAIL A

TYPICAL

32-Lead TSOP Package (T)
Order Number NM27LV010BTXXX
Package Number MBH32A

MEH 32A (REV B)

NM27LV010B 1,048,576-Bit (128k x 8) Low Voltage EPROM

Physical Dimensions inches (millimeters) unless otherwise noted (Continued)

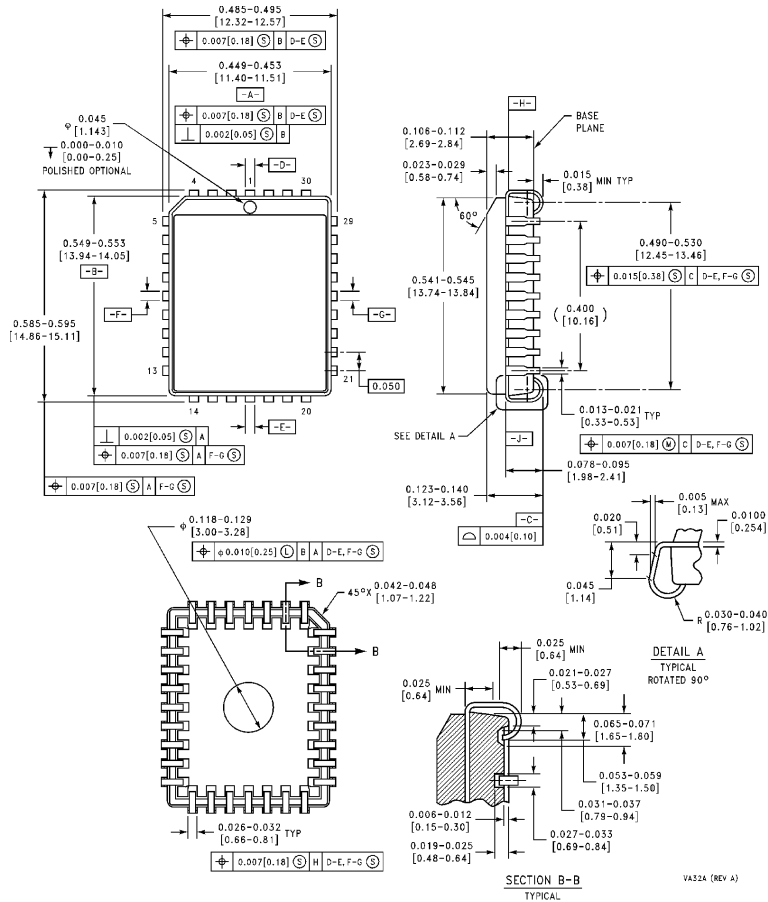

32-Lead PLCC Package (V)
Order Number NM27LV010BVXXX
Package Number VA32A

LIFE SUPPORT POLICY

FAIRCHILD'S PRODUCTS ARE NOT AUTHORIZED FOR USE AS CRITICAL COMPONENTS IN LIFE SUPPORT DEVICES OR SYSTEMS WITHOUT THE EXPRESS WRITTEN APPROVAL OF THE PRESIDENT OF FAIRCHILD SEMICONDUCTOR CORPORATION. As used herein:

1. Life support devices or systems are devices or systems which, (a) are intended for surgical implant into the body, or (b) support or sustain life, and (c) whose failure to perform when properly used in accordance with instructions for use provided in the labeling, can be reasonably expected to result in a significant injury to the user.
2. A critical component in any component of a life support device or system whose failure to perform can be reasonably expected to cause the failure of the life support device or system, or to affect its safety or effectiveness.

Fairchild Semiconductor Corporation Americas
 Customer Response Center
 Tel: 1-888-522-5372

Fairchild Semiconductor Europe
 Fax: +49 (0) 1 80-530 85 86
 Email: europe.support@nsc.com
 Deutsch Tel: +49 (0) 8 141-35-0
 English Tel: +44 (0) 1 793-85-68-56
 Italy Tel: +39 (0) 2 57 5631

Fairchild Semiconductor Hong Kong Ltd.
 13th Floor, Straight Block,
 Ocean Centre, 5 Canton Rd.
 Tsimshatsui, Kowloon
 Hong Kong
 Tel: +852 2737-7200
 Fax: +852 2314-0061

National Semiconductor Japan Ltd.
 Tel: 81-3-5620-6175
 Fax: 81-3-5620-6179

www.fairchildsemi.com

Fairchild does not assume any responsibility for use of any circuitry described, no circuit patent licenses are implied and Fairchild reserves the right at any time without notice to change said circuitry and specifications.